

# MODEL CFX-431

Triplexer  
for HF, VHF, UHF

## Instruction Manual

Thank you for your purchasing our product.

Model CFX-431 is the Triplexer for transmitting/receiving all 3 bands of HF-150MHz, 400MHz band and 900MHz band at the same time. Using one, or two CFX-431, you can connect transceivers and antennas by one coaxial cable.

The combined high quality filters of CFX-431 work to prevent occurrence of TVI on the other hand. (Isolation of each connectors are over 50dB.)

When using CFX-431 for one frequency, the other connectors can be remain as [open], but additional dummy load will be much better.

### Specifications

- Band pass Frequency & insertion loss
  - 1.3 ~ 150MHz / 0.2dB or less
  - 400 ~ 500MHz / 0.3dB or less
  - 900 ~ 1400MHz / 0.4dB or less
- Impedance : 50Ω
- VSWR : 1.2 or less
- Max. Input power : 1.3-60MHz / 1000W(PEP)  
100-150MHz / 800W(PEP)  
400-500MHz / 500W(PEP)  
900-1400MHz / 200W(PEP)
- Isolation : more than 50dB
- Connector : see below chart
- Chassis Dimension : 66(W)×90(D)×26(H) [mm]



Connection sample1

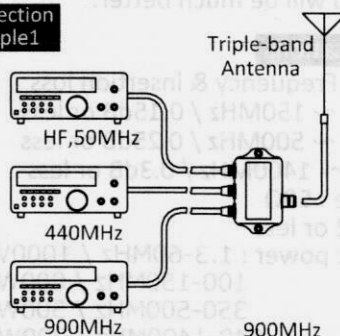

Connection sample2

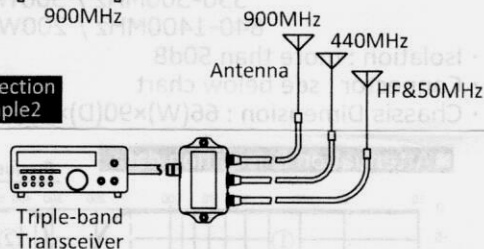

Connection sample3

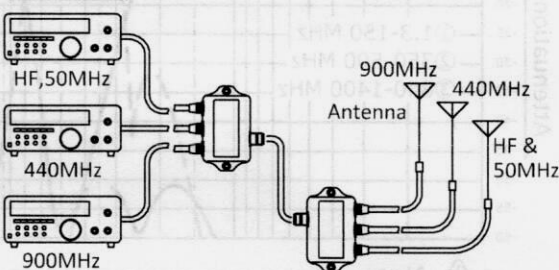

### Attenuation & Isolation data

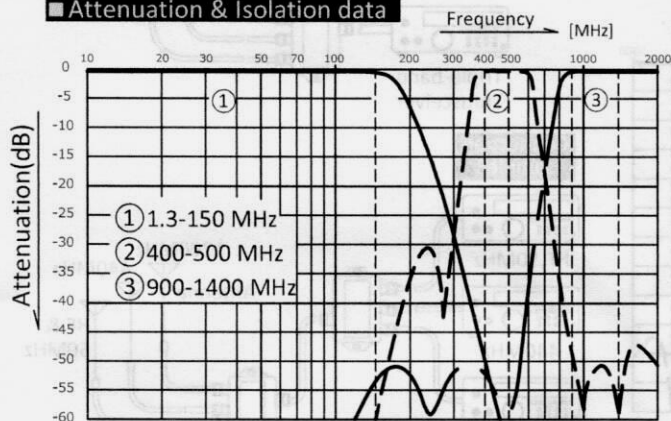

### Note:

- CFX-431 is for mobile and indoor use.
- For outdoor use, sufficient water-proof works is required.

### 【After-Sales Service】

We provide the replacement parts for the damages by unintentional accidents or for deterioration with long-term use. Please ask the local shop you purchased this product. This product is made under the stringent quality control. Should there be any breakage in transit, please do not hesitate to contact the shop you purchased this product.

- Appearance and specifications are subject to change without notice.

**COMET CO.,LTD.**

4-18-2, Tsuji, Minami-ku, Saitama-shi, Saitama-Pref, 336-0026, JAPAN

TEL : 81-48-839-3131 / FAX : 81-48-839-3136

URL : <http://www.comet-ant.co.jp/english>

### Connector Type

	CFX-431A	CFX-431B
COM	N-J	N-J
HF-150MHz	PL-259 [M-P] (with cable)	PL-259 [M-P] (with cable)
400MHz	N-P (with cable)	PL-259 [M-P] (with cable)
900MHz	N-P (with cable)	N-P (with cable)

Printed in JAPAN, 2nd edition.

Copyright (C) 2015 COMET CO.,LTD. All Rights Reserved.